









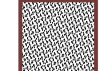
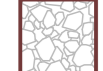

KEY:-

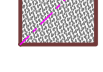
-  EXISTING GRASS AREAS
-  EXISTING PAVING
-  EXISTING BITMAC SURFACE/PATH
-  EXISTING ROCK FACE ARMOUR
-  PROPOSED COLUMN LIGHTING
-  PROPOSED BOLLARD LIGHTING
-  PROPOSED DUCTING (HARD DIG)
-  PROPOSED DUCTING (SOFT DIG)
-  PROPOSED BENCH SEATING (EXISTING STONE)
-  PROPOSED BENCH SEATING (EXISTING PLASTIC)
-  PROPOSED PICNIC TABLES (EXISTING PLASTIC)
-  SITE BOUNDARY
-  PROPOSED TREE PLANTING
PINUS PINASTER 5X TRANSPLANTED 2M WIDE X 3.5M TALL, ROOT BALLED WITH LEADER & LATERAL. PLANT AS SHOWN ON LAYOUT
-  PROPOSED PLANTING AROUND EXISTING WWTW
ESCALLONIA IVEYI IN 2L POTS SPACED AS PER PLAN

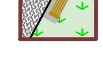

BENCH SEAT TYPE (ASF)

UNPAINTED STEEL FRAMEWORK AND POSTS WITH ROUND TUBULAR SLATS
FITTED WITH 40MM X 25MM TUBULAR SLATS. THE SEAT AND BACKREST ARE
CONSTRUCTED FROM 40MM X 25MM TUBULAR SLATS. THE SEAT AND
BACKREST ARE 1800MM LONG. THE SEAT IS 450MM HIGH. THE
BACKREST IS 850MM HIGH. THE SEAT AND BACKREST ARE
CONNECTED BY 40MM X 25MM TUBULAR SLATS. THE SEAT AND
BACKREST ARE FINISHED WITH AN ANTI-RUST COATING. THE SEAT
AND BACKREST ARE FINISHED WITH AN ANTI-RUST COATING. THE
SEAT AND BACKREST ARE FINISHED WITH AN ANTI-RUST COATING.



BENCH TYPE (ASF) - INDIVIDUAL BENCH - ELEVATION

In addition to the hazards/risks normally associated with the types of work detailed on this drawing take note of above. It is assumed that all works on this drawing will be carried out by a competent contractor working, where appropriate, to an appropriate method statement.

SAFETY, HEALTH AND ENVIRONMENTAL INFORMATION BOX

Ards & North Down Borough Council accepts no liability for any use of this document and it is intended only for the purposes for which it was prepared and provided. Only written dimensions shall be used.
Contractor to confirm all dimensions.
© Ards and North Down Borough Council

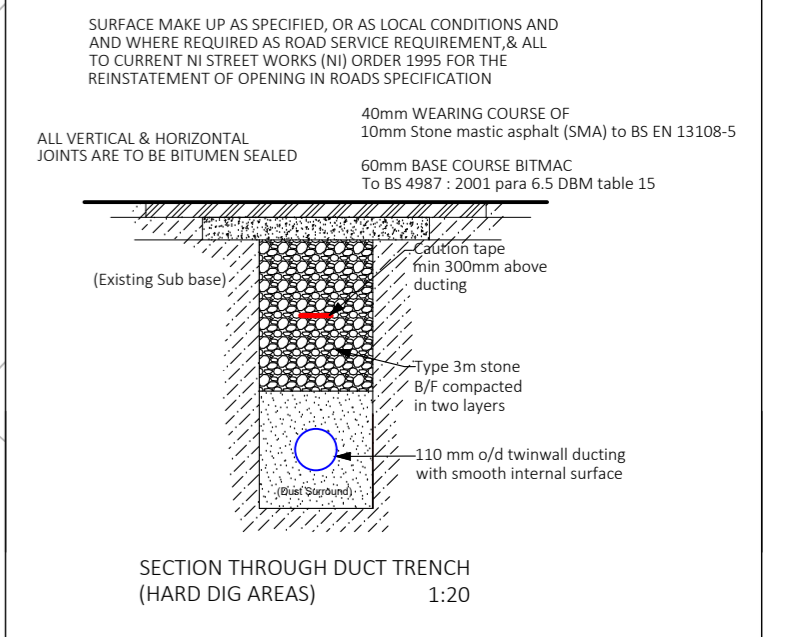
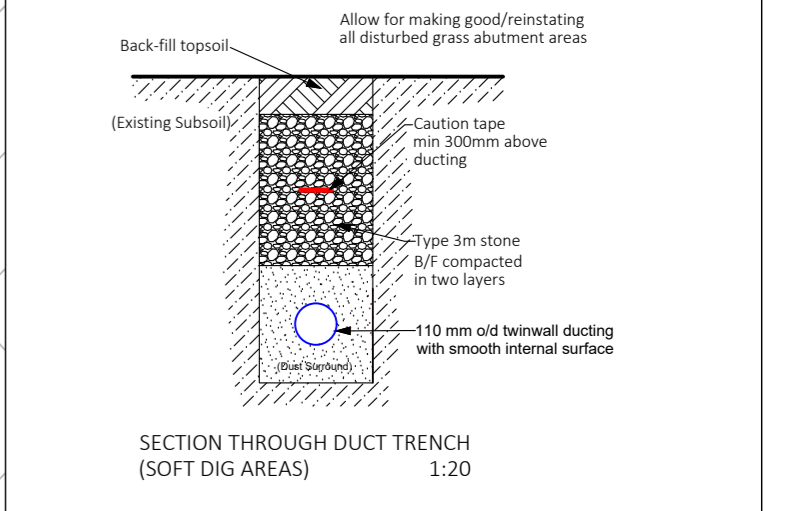
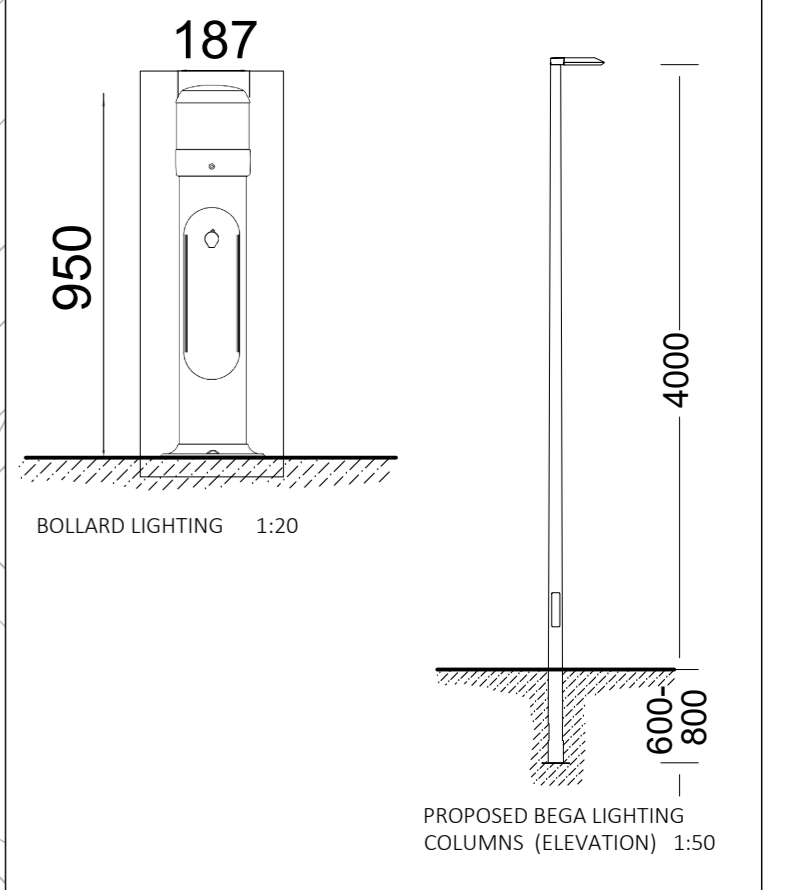
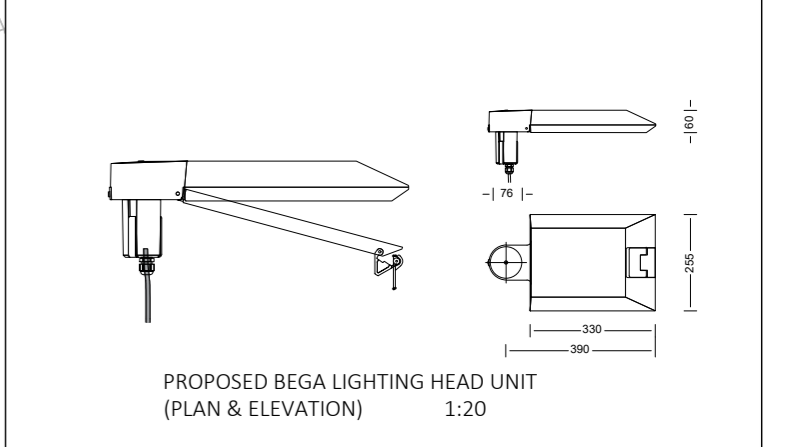

REVISION A - 05/10/23 - LIGHTING REVISED TO PROVIDE BOLLARD LIGHTING TO NORTHERN AREA AT CARPARK ACCESS	PH/GS	05/10/23	A
REVISION B - 29/02/24 LIGHTING COLUMNS DIMENSIONED AT 4000mm AND SCALE ADDED	PH/GS	29/02/24	B

Revision Details	By	Check	Date	Suffix

Purpose of issue
PLANNING APPLICATION

Client
AANDBC

Project Title
KIRCUBBIN PROMENADE LIGHTING AND FIXTURES

Drawing Title
SITE PLAN LAYOUT PROPOSED

Designed PH	Drawn PH	Checked GS	Approved PC	Date 02.03.23
Ards & North Down Council Internal Project No.				
Project No N/A				
Scale @ A1 1:500				

Ards and North Down Borough Council
Town Hall, The Castle
Bangor
BT20 4BT
T: 0300 013 3333
www.ardsandnorthdown.gov.uk

Drawing Number
RG/23/KP/02

Rev
A

